

## VACANCY PLAN

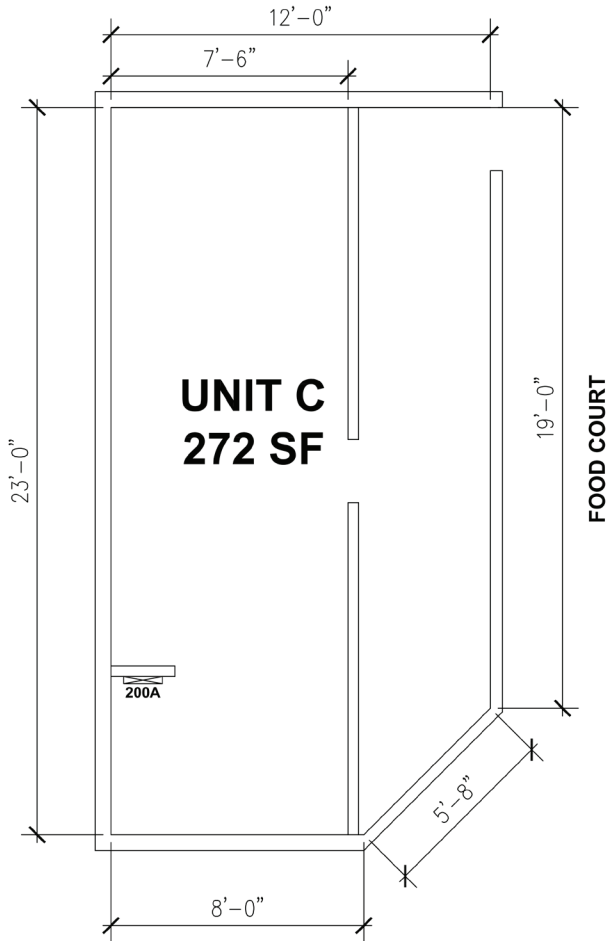

## SITE PLAN



## UNIT DETAILS

<b>Date Available</b>	Immediately
<b>Description</b>	Good food court location with recent storefront renovations and located next to busy Wellington Medical Clinic entrance.

## CONTACT

Ingus Silgailis  
VP, Leasing  
T 604 629 8130  
C 604 230 3435  
ingus@nwproperties.ca

Christoph Richter  
VP, Portfolio Management  
T 604 629 8132  
C 604 220 3286  
christoph@nwproperties.ca

Dave Mills  
Property Manager  
T 250 758 1102  
C 250 713 6451  
dave@nwproperties.ca

[nwproperties.ca](http://nwproperties.ca)