

VACANCY PLAN

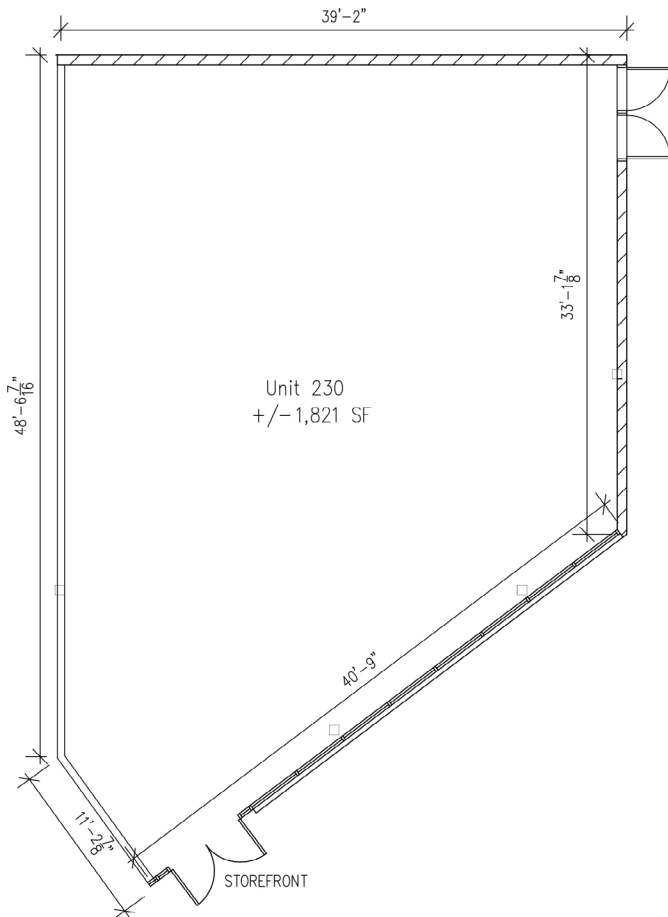

SITE PLAN



UNIT DETAILS

Date Available	Immediately
Description	End unit with convenient parking in front and good visibility from Notre Dame Drive.

CONTACT

Ingus Silgailis
VP, Leasing
T 604 629 8130
C 604 230 3435
ingus@nwproperties.ca

Christoph Richter
VP, Portfolio Management
T 604 629 8132
C 604 220 3286
christoph@nwproperties.ca

Kyle Silgailis
Property Manager
T 604 629 8121
C 604 329 7337
kyle@nwproperties.ca

nwproperties.ca