

VACANCY PLAN

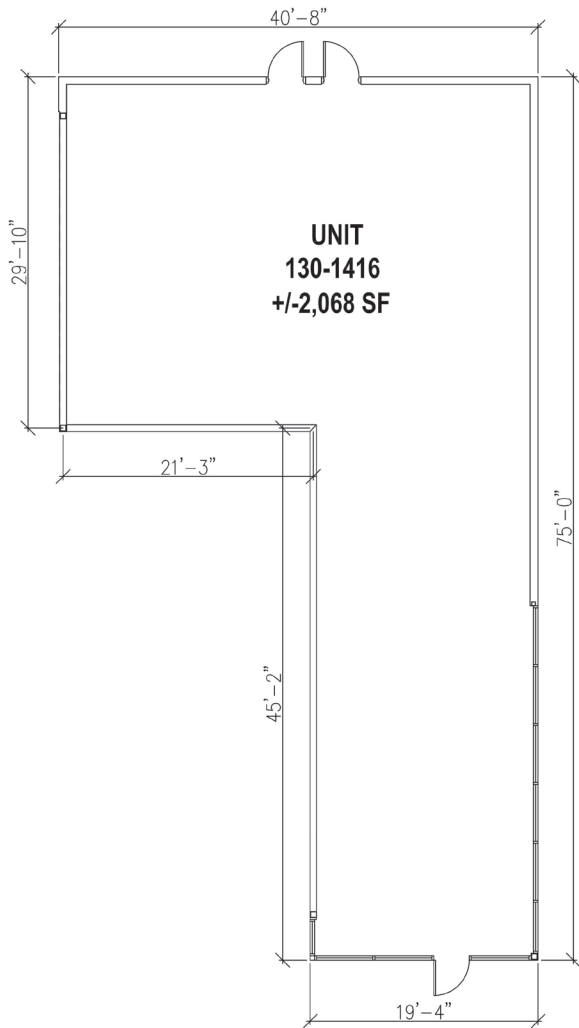

SITE PLAN



UNIT DETAILS

Date Available	Immediately
Description	Unit is located near the main traffic intersection of the shopping centre and across from Moxie's Restaurant. Can be combined with Unit 132-1416 to create a larger unit if desired.

CONTACT

Ingus Silgailis
VP, Leasing
T 604 629 8130
C 604 230 3435
ingus@nwproperties.ca

Christoph Richter
VP, Portfolio Management
T 604 629 8132
C 604 220 3286
christoph@nwproperties.ca

Dave Mills
Property Manager
T 250 758 1102
C 250 713 6451
dave@nwproperties.ca

nwproperties.ca